

# New!

## True Position® Retainers with Backing Plates

Dayton Single Punch True Position® Retainers—the recognized industry standard—are now available with an integrated hardened backing plate. With all the features of the original True Position® Retainer, this new retainer satisfies the needs of applications where more bearing surface is desired. All True Position® Retainers are available in both inch and metric sizes.



Heavy Duty

True Position®  
gives you true dimensional  
accuracy each and every time!

True Position®  
Single Punch  
Retainers  
(Inch and Metric)

# BAILLOCK



Global leader in  
quality metal fabrication  
and stamping tools

[www.daytonprogress.com](http://www.daytonprogress.com)

# True Position® Retainers

Fitting isolated punches or pilots onto a die set is quick and easy with True Position® Retainers. The in-line dowel directly over the punch guarantees precise alignment.

Dayton's True Position® Retainers are recognized as the standard in the industry for interchangeability.

**HRTB/BRTB  
Heavy Duty**



# Backing Plates

The Backing Plate has the same function as the original backing *plug* model True Position® Retainer, i.e., to prevent the punch shank from penetrating the punch plate. Backing Plates cover the entire surface of the retainer, spreading the load over a large area.

For optimum resistance on impact, True Position® Retainers have hardened Backing Plates.

Heavy Duty	Code	D	A	B	G	K	R	S	U	X	Y	Screw Size
HRTB	37	.3750	1.75	1.72	.438	.750	.38	.47	1.060	.354	.295	5/16-18
HRTB	50	.5000	2.00	1.97	.562	.750	.50	.60	1.180	.472	.256	3/8-16
HRTB	62	.6250	2.12	2.09	.625	.750	.56	.66	1.250	.532	.236	3/8-16
HRTB	75	.7500	2.38	2.34	.688	.750	.69	.79	1.320	.650	.197	3/8-16
HRTB	87	.8750	2.50	2.47	.688	.750	.75	.85	1.400	.728	.197	3/8-16
HRTB	100	1.0000	2.75	2.72	.781	.938	.88	.97	1.600	.866	.276	1/2-13
HRTB	125	1.2500	2.75	2.72	.781	.938	.88	.97	1.600	.866	.276	1/2-13

Inch

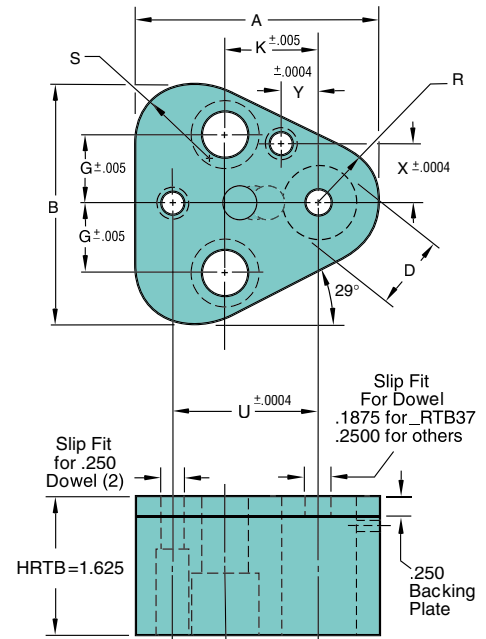

### HOW TO ORDER

**Specify:** Qty. Code D  
 Example: 23 HRTB 37  
 13 BRTB 25

True Position® Retainer sets include:

- Ball
- Spring
- Screws
- Dowels
- Ball Release Set Screw



Heavy Duty	Code	D	A	B	G	K	R	S	U	X	Y	Screw Size
BRTB	10	10.00	44.5	43.7	11.1	19.0	9.5	12.0	26.925	9.0	7.5	M8
BRTB	13	13.00	50.8	50.0	14.3	19.0	12.7	15.2	29.970	12.0	6.5	M8
BRTB	16	16.00	54.0	53.2	15.9	19.0	14.3	16.8	31.750	13.5	6.0	M8
BRTB	20	20.00	60.3	59.5	17.5	19.0	17.5	20.0	33.530	16.5	5.0	M10
BRTB	25	25.00	69.9	69.1	19.8	23.8	22.2	24.7	40.640	22.0	7.0	M12
BRTB	32	32.00	69.9	69.1	19.8	23.8	22.2	24.7	40.640	22.0	7.0	M12
BRTB	40	40.00	77.4	76.6	24.0	27.0	26.0	28.5	43.993	26.0	10.0	M12

BRTB conforms to the NAAMS™ Standard for Ball Lock Punch Retainers.

Metric

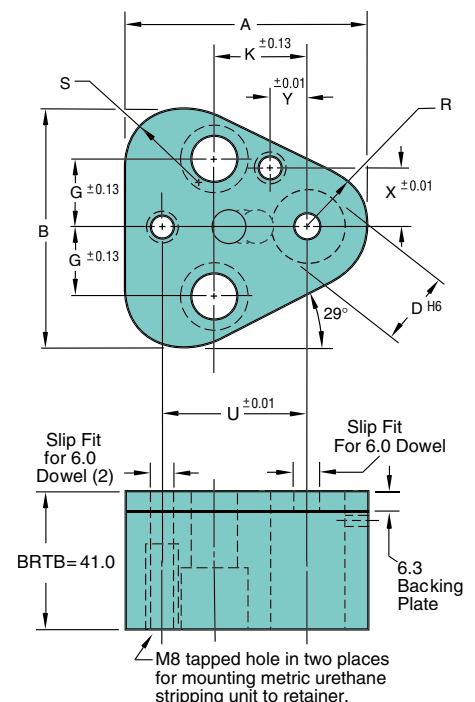

DAYTON PROGRESS CORPORATION • 500 Progress Road • P.O. Box 39 • Dayton, OH 45449-0039 • USA  
 Telephone: 937-859-5111 • Fax: 937-859-5353 • www.daytonprogress.com

Form 995 9/04