



Thread Forming Punch and Matrix Units

For type B and AB sheet metal screws

Thread forming in sheet metal can be less expensive than using machine screws and nuts, not only in the cost of the product, but in ease and speed of assembly. The thread form in sheet metal is developed in one step or one station of the die. The hole is punched, the material is lanced and a helical spiral is formed to the proper thread helix of a type B and AB sheet metal screw.

This design has excellent holding power against vibration. It actually locks the screw in place when tightened due to the tension built up in the material.

- No need for lock nuts.
- No chance of cross threading.
- No extra parts to misplace.

One screw through the components to be assembled is all that is necessary.

Material thickness limitations are shown on the back of this page. Coining the area to thin the material in a previous station in the die can be used for thicker material. Keep in mind that coining work hardens the material. The harder area will affect tool life.

Thread Conversion

Most sheet metal screws are actually standard inch sizes that are converted into millimeter dimensions. If screws cannot be found in metric sizes the equivalent inch size is shown under the illustration at the right.

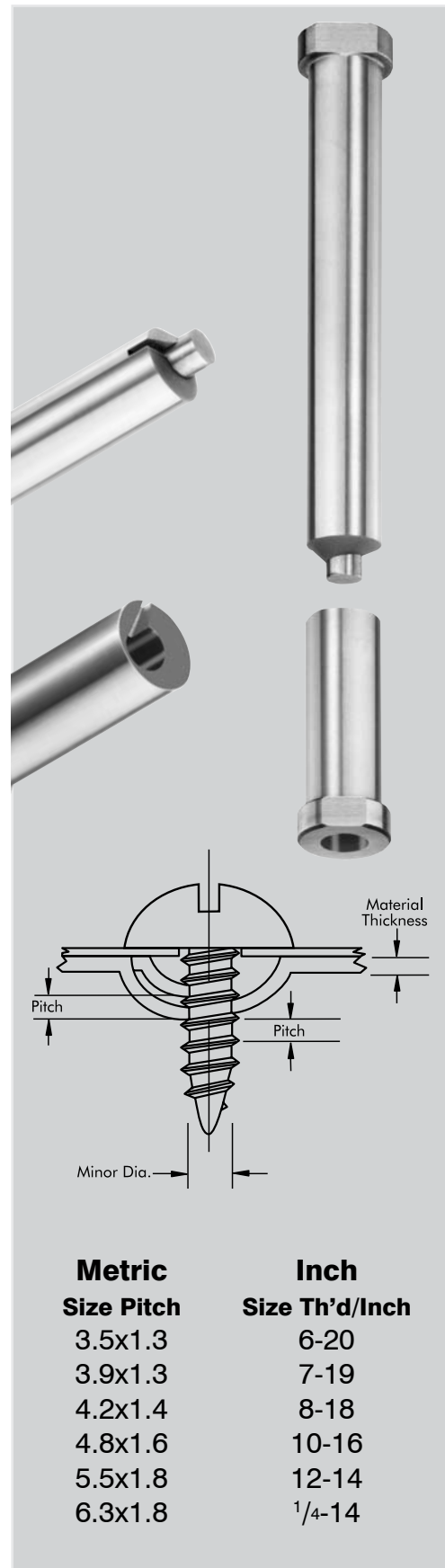

Sold In Sets Only

Steel:	RC
A2	60-64

Form Punch

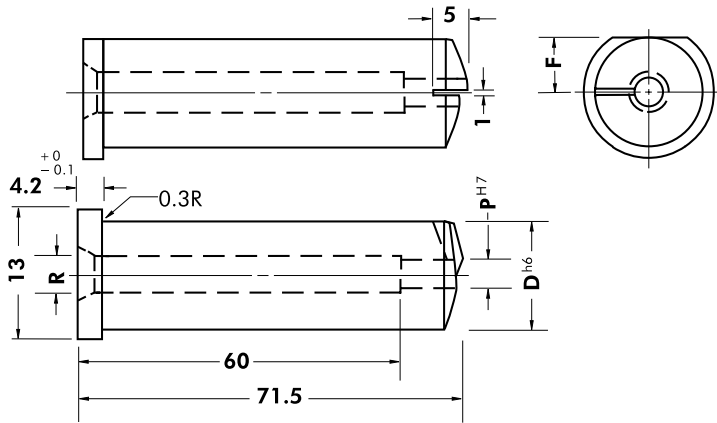

Pierce Punch

DIN 9861

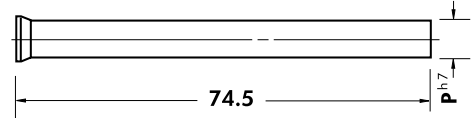

Screw Size	D	W	P	R
B3.5	7.5	3.75	2.7	3.1
B3.9	7.5	3.75	3.0	3.6
B4.2	8.0	4.00	3.1	3.7
B4.8	8.0	4.00	3.8	4.5
B5.5	8.0	4.00	4.3	5.0
B6.3	10.0	5.00	4.8	5.5

How to Order:

Qty.	Catalog No.
2	262498
1	262544

Matrix

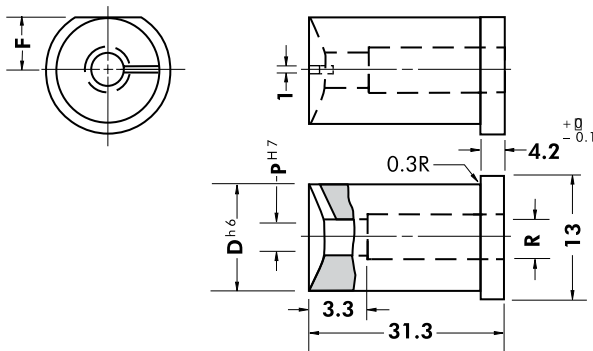

Screw Size	Material Thickness (max.)
≤ 3.9	0.6 (.024")
4.2	0.8 (.031")
4.8	0.9 (.035")
≥ 5.5	1.0 (.039")

Set consists of:

- 1 Form Punch
- 1 Pierce Punch
- 1 Matrix

Complete Set Punches and Matrix

Screw Size	D	W	P	R
B3.5	7.5	3.75	2.75	3.2
B3.9	7.5	3.75	3.05	3.4
B4.2	8.5	4.25	3.15	3.5
B4.8	9.0	4.50	3.85	4.2
B5.5	9.0	4.50	4.35	4.8
B6.3	10.5	5.25	4.85	5.3

Catalog Number	
B3.5	262498
B3.9	262501
B4.2	262528
B4.8	262536
B5.5	262544
B6.3	262552



DAYTON PROGRESS CORPORATION • 500 Progress Road • P.O. Box 39 • Dayton, OH 45449-0039 • USA
 Telephone: 937-859-5111 • Fax: 937-859-5353 • Web: www.daytonprogress.com