



Daycast™ Core Pins

For Die Casting and Other Casting and Molding Processes

Daycast Core Pins are given a special heat treating process providing an excellent balance of toughness and wear resistance. The wear resistance properties and improved toughness characteristics of Daycast make it an excellent choice for long run applications. Daycast Core Pins are austenitized in an atmospherically controlled furnace at a temperature that provides them with maximum resistance to tempering.

- Precision points on pins up to 6.00 inches are available.
- Superior finish minimizes wear.
- Hardened to Rc 58-60.
- Precision point length and overall length on pointed pins.
- Precision head thickness.

Blanks

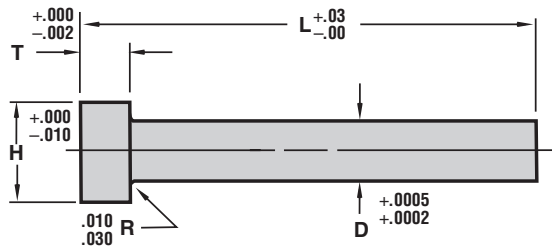

Precision Ground Points

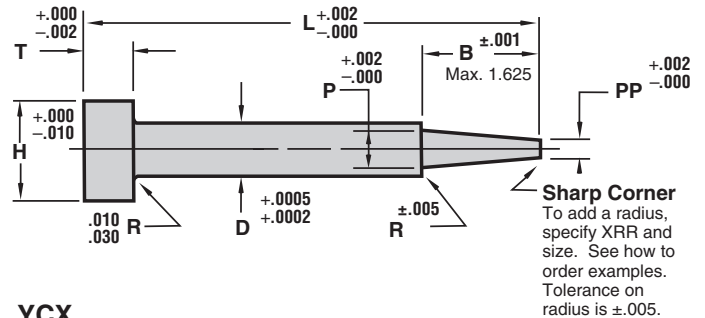

YCB

Catalog Number	D	Head Dims		Standard Lengths (L)			
		H	T	3.00	4.00	5.00	6.00
YCB125	1/8	1/4	1/8	300	400	500	600
YCB140	9/64	1/4	1/8				
YCB156	5/32	9/32	5/32				
YCB171	11/64	11/32	3/16				
YCB187	3/16	3/8	3/16				
YCB203	13/64	3/8	3/16	300	400	500	600
YCB218	7/32	13/32	3/16				
YCB250	1/4	7/16	3/16				
YCB281	9/32	7/16	1/4				
YCB312	5/16	1/2	1/4				
YCB343	11/32	9/16	1/4	300	400	500	600
YCB375	3/8	5/8	1/4				
YCB406	13/32	11/16	1/4				
YCB437	7/16	11/16	1/4				
YCB468	15/32	3/4	1/4				
YCB500	1/2	3/4	1/4	300	400	500	600

YCX

Catalog Number	D	Head Dims		Standard Lengths (L)	
		H	T	Up to 5.00	5.00—6.00
YCX125	1/8	1/4	1/8		
YCX140	9/64	1/4	1/8		
YCX156	5/32	9/32	5/32		
YCX171	11/64	11/32	3/16		
YCX187	3/16	3/8	3/16		
YCX203	13/64	3/8	3/16		
YCX218	7/32	13/32	3/16		
YCX250	1/4	7/16	3/16		
YCX281	9/32	7/16	1/4		
YCX312	5/16	1/2	1/4		
YCX343	11/32	9/16	1/4		
YCX375	3/8	5/8	1/4		
YCX406	13/32	11/16	1/4		
YCX437	7/16	11/16	1/4		
YCX468	15/32	3/4	1/4		
YCX500	1/2	3/4	1/4		

HOW TO ORDER

Specify: Qty. Catalog # Length Special Length (optional)
 Example: 12 YCB171- 400

HOW TO ORDER

Specify: Qty. Catalog # P, PP, L, B, R, XRR (optional)
 Example: 18 YCX312, P.250, PP.224, L.2.920, B.750, R.030
 18 YCX375, P.356, PP.330, L.5.250, B.750, R.015, XRR.030



1 to 19 pieces 1 day
 20+ pieces per quote

FDS is the number of working days to shipment following the receipt of your order.



DAYTON PROGRESS CORPORATION • 500 Progress Road • P.O. Box 39 • Dayton, OH 45449-0039 • USA
 Telephone: 937-859-5111 • www.daytonprogress.com • Fax: 937-859-5353